

MQ6 Sensor

Miniature Double ended sensor



DESCRIPTION

The double shear beam type sensor has small size, unibody design, surface plating rose gold, double waterproof connectors, etc.

Moisture proof sealed, ideal for hostile environment, Simple to install, easy to use, good interchangeability suitable for electronic truck scale, railroad scale, hopper scale and various special scales.

OUTLINE DIMENSIONS in millimeters (mm)

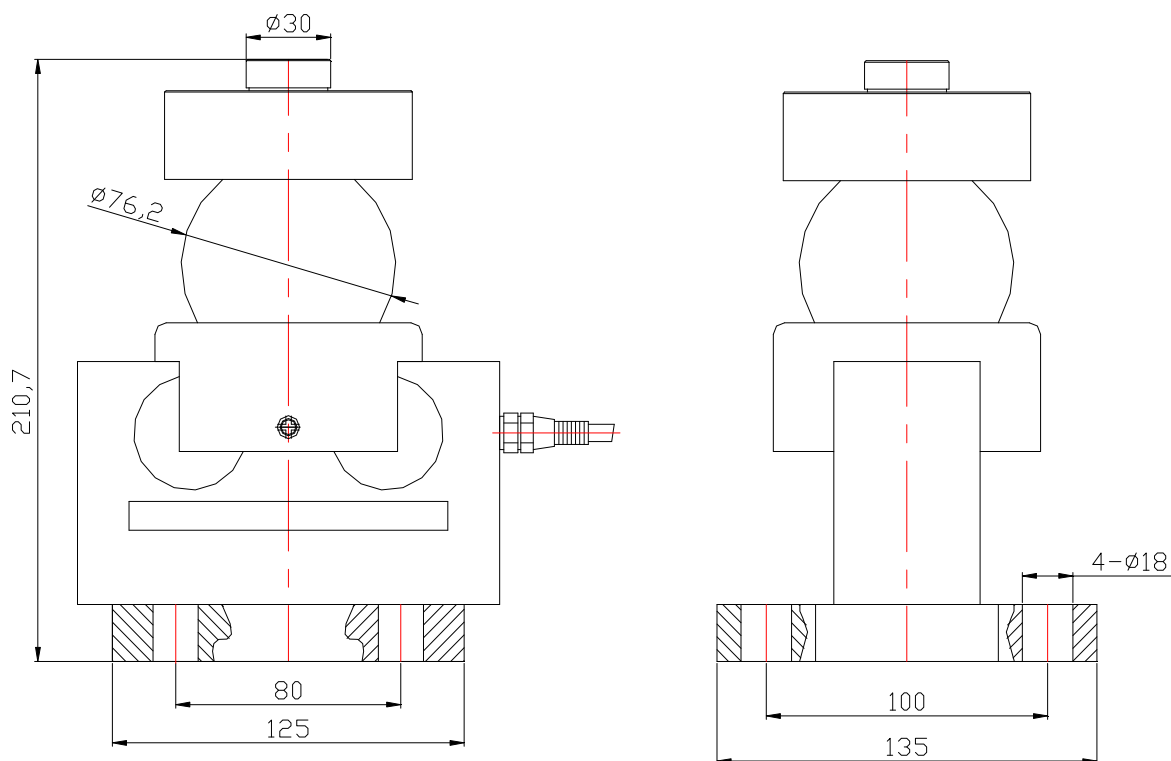

SPECIFICATIONS

Capacity	t	10, 20, 25, 30, 40
Rated output	mv/v	2.0±0.1%
Non-linearity	%F.S	0.03
Hysteresis	%F.S	0.03
Creep in 30 minutes	%F.S	0.03
Zero balance	%F.S	±1
Input resistance	Ω	770±10
Output resistance	Ω	700±5
Insulation resistance	MΩ	≥5000
Excitation voltage	V	10V (maximum 15V) AC/DC
Environmental protection		IP67
Safe overload	%F.S	150
Ultimate overload	%F.S	300
Operating temperature range	°C	-10~+40
Material		Alloy steel
Cable Length	m	

Wiring Schematic Diagram

