

# Sensor Accessory



## OUTLINE DIMENSIONS in millimeters

### DESCRIPTION

Easy installation, good self-aligning ability, anti-reversal ability.

Stainless steel construction, anti-corrosion, can be used under hazardous environments. mainly used for platform scales, automobile testing facilities, electronic truck scales and other electronic weighing devices. form a complete set of sensor MZ3

### Z301A

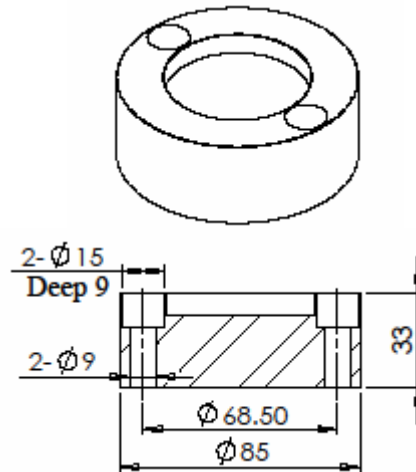
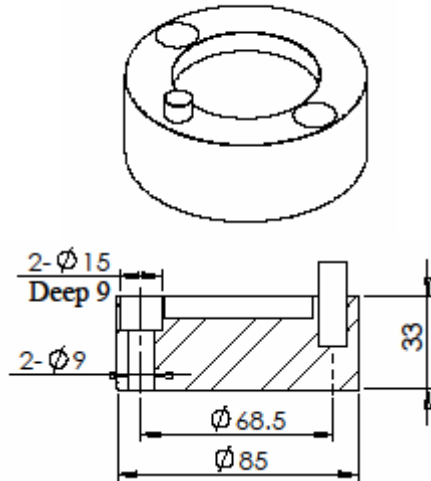

### Z301B

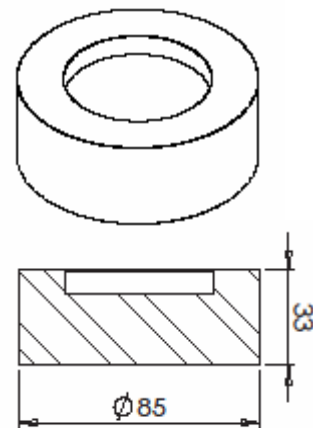
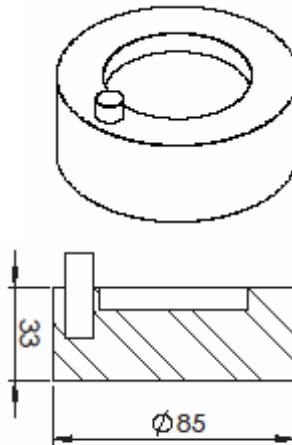

### Z302

