

MSB4 Sensor

Single-Ended Beam



DESCRIPTION

It is a high performance stainless steel beam type sensor, an integral mounting step removes the need for spacer plates. This product is suitable for small and medium platform scales, pallet weighers and process weighing..

OUTLINE DIMENSIONS in millimeters (mm)

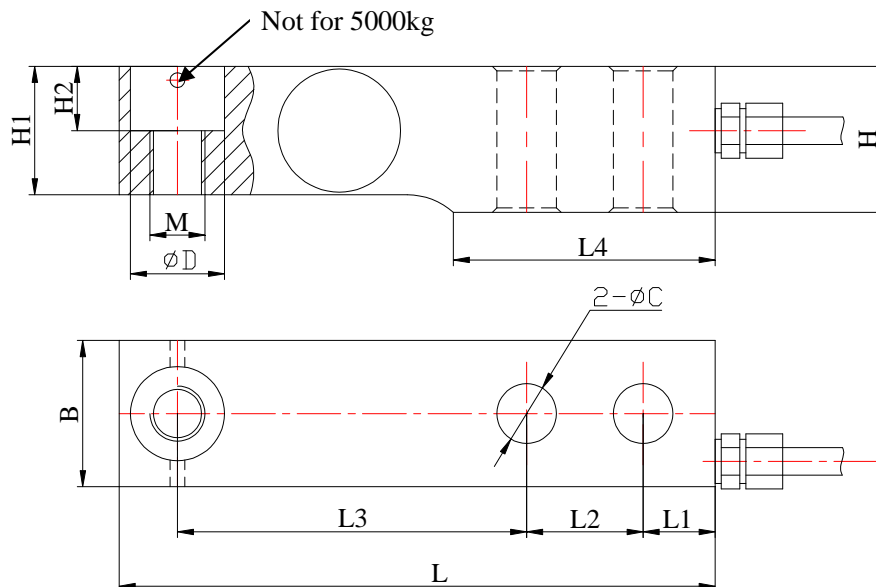

Capacity (kg)	Size mm											
	L	L1	L2	L3	L4	H	H1	H2	B	2-ΦC	ΦD	M
250	130	15.5	25.4	76.2	57.1	31.8	25.2	14.2	31.8	13	20.5	M 12
500	130	15.5	25.4	76.2	57.1	31.8	26	14.2	31.8	13	20.5	M 12
1000	130	15.5	25.4	76.2	57.1	31.8	27.95	14.2	31.8	13	20.5	M 12
2000	130	15.5	25.4	76.2	57.1	35.8	31.95	14.2	31.8	13	20.5	M 12
5000	172	19.1	38.1	95.3	76.2	44	40	20	38	20.5	30.2	M20

SPECIFICATIONS

Capacity	kg	250,500,1000,2000,5000
Rated output	mv/v	2.0±0.5%
Non-linearity	%F.S	0.03
Hysteresis	%F.S	0.03
Creep in 30 minutes	%F.S	0.03
Zero balance	%F.S	±1
Input resistance	Ω	1000±50
Output resistance	Ω	1000±10
Insulation resistance	MΩ	≥5000
Excitation voltage	V	10V (maximum 15V) AC/DC
Environmental protection		IP67
Safe overload	%F.S	150
Ultimate overload	%F.S	300
Operating temperature range	°C	-10~+40
Material		Alloy steel & Stainless steel
Cable Length	m	3m (500~1000kg) 6m(2000~5000kg)

Wiring Schematic Diagram

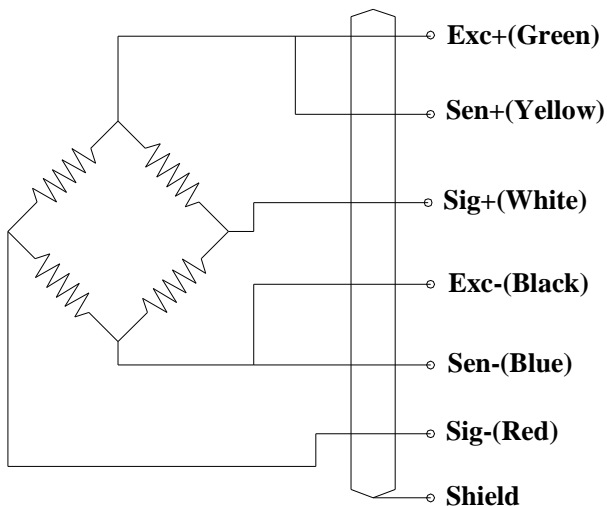

FEATURE

- Capacities 250kg~5000kg
- Low profile, stainless steel construction
- Applications Platform scales, Belt scales, Silo hopper weighing

INTERCHANGEABLE PRODUCTS

- VISHAY Model ACB