

# MBH1 Sensor



## DESCRIPTION

Suitable for crane scale, hopper scale, packing scale, overload limiter.

## OUTLINE DIMENSIONS in millimeters (mm)

### 15~30t

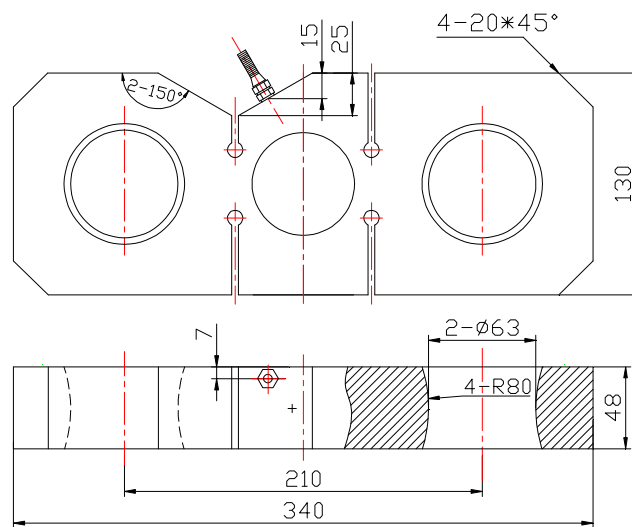

### 50t

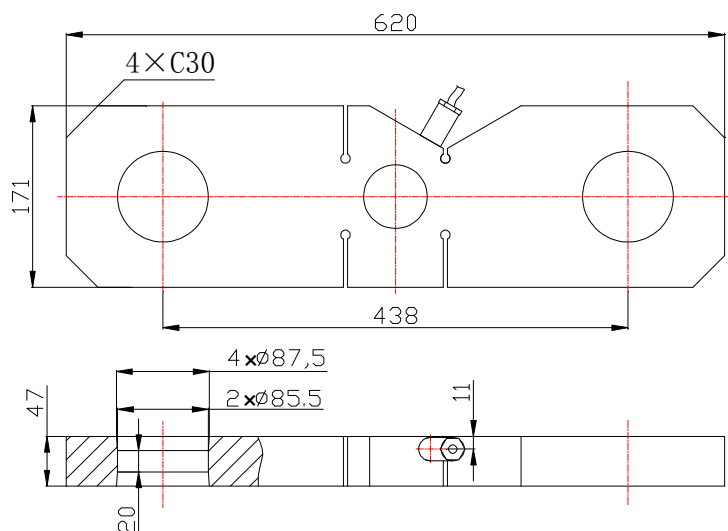

## SPECIFICATIONS

Capacity	t	15,20,30,50
Rated output	mv/v	2.0±0.1%
Non-linearity	%F.S	0.03
Hysteresis	%F.S	0.03
Creep in 30 minutes	%F.S	0.03
Zero balance	%F.S	±1
Input resistance	Ω	400±10
Output resistance	Ω	352±3
Insulation resistance	MΩ	≥5000
Excitation voltage	V	10V (maximum 15V) AC/DC
Environmental protection		IP67
Safe overload	%F.S	150
Ultimate overload	%F.S	300
Operating temperature range	°C	-10~+40
Material		Alloy steel
Cable Length	m	12m, (50t)10m

## Wiring Schematic Diagram

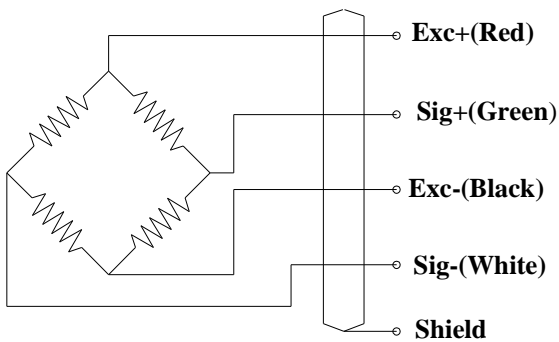

## FEATURE

- Capacities 15~50t
- Nickel plated alloy steel construction
- Suitable for crane scale, hopper scale, packing scale, overload limiter

## INTERCHANGEABLE PRODUCTS

KELI Model BHS