

# MSB7 Sensor

## Single-Ended Beam



### DESCRIPTION

Single shear beam structure design, installation with flexibility, Alloy Steel materials, internal irrigation rubber seal, oil, waterproof, corrosion resistance, can be applied to various environment. Applications Platform scales, Belt scales, Silo hopper weighing.

### OUTLINE DIMENSIONS in millimeters (mm)

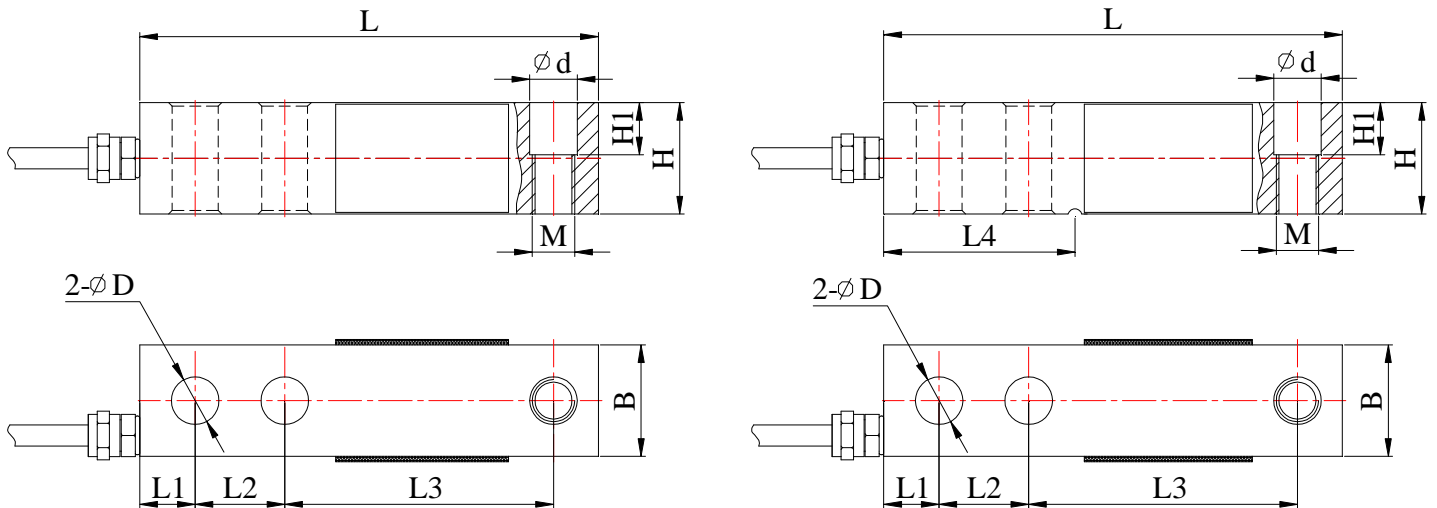

Capacity	Size mm (inch)									
	L	L1	L2	L3	H	H1	B	ΦD	Φd	M
0.5~2t	130 (5.12)	15.8 (0.62)	25.4 (1.0)	76.2 (3.0)	31.8 (1.25)	15.8 (0.62)	31.8 (1.25)	13.5 (0.53)	13.5 (0.53)	M12×1.75
1Klb~4Klb	130 (5.12)	15.8 (0.62)	25.4 (1.0)	76.2 (3.0)	31.8 (1.25)	15.8 (0.62)	31.8 (1.25)	13.5 (0.53)	13.5 (0.53)	1/2-20UNF
5KSE	130 (5.12)	15.8 (0.62)	25.4 (1.0)	76.2 (3.0)	31.8 (1.25)	15.8 (0.62)	31.8 (1.25)	13.5 (0.53)	13.5 (0.53)	1/2-20UNF
2.5~5t	171.5 (6.75)	19.1 (0.75)	38.1 (1.5)	95.3 (3.75)	38.1 (1.5)	18.8 (0.74)	38.1 (1.5)	19.8 (0.78)	19.8 (0.78)	M18×1.5
5K~10Klb	171.5 (6.75)	19.1 (0.75)	38.1 (1.5)	95.3 (3.75)	38.1 (1.5)	18.8 (0.74)	38.1 (1.5)	19.8 (0.78)	19.8 (0.78)	3/4-16UNF
10t	222.3 (8.75)	25.4 (1.0)	50.8 (2.0)	101.6 (4.0)	50.8 (2.0)	25.4 (1.0)	50.8 (2.0)	26.92 (1.06)	26 (1.02)	M24×2
20Klb	222.3 (8.75)	25.4 (1.0)	50.8 (2.0)	101.6 (4.0)	50.8 (2.0)	25.4 (1.0)	50.8 (2.0)	26.92 (1.06)	26 (1.02)	1-12UNF

## SPECIFICATIONS

Capacity	kg	500,1000,1500,2000,2500,3000,5000,10000kg
	Klb	1,1.5,2,2.5,3,4, 5KSE ,5 ,7.5,10,20
Rated output	mv/v	2.0±0.1%/3.0±0.1%
Non-linearity	%F.S	0.03, 0.02
Hysteresis	%F.S	0.03, 0.02
Creep in 30 minutes	%F.S	0.03, 0.02
Zero balance	%F.S	±1
Input resistance	Ω	350±3.5
Output resistance	Ω	350±3.5
Insulation resistance	MΩ	≥5000
Excitation voltage	V	10V (maximum 15V) AC/DC
Environmental protection		IP67
Safe overload	%F.S	150
Ultimate overload	%F.S	300
Operating temperature range	℃	-10~+40
Material		Alloy steel & Stainless steel
Cable Length	m	4m(0.5~2t),6m(2.5~10t,1Klb~20Klb)

## Wiring Schematic Diagram

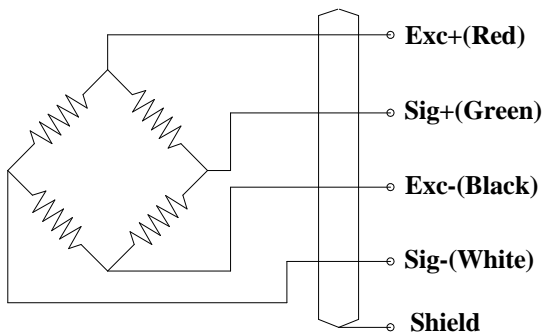

## FEATURE

- Capacities 500kg~10000kg , 1Klb~20Klb
- Mounting height low, long-term stability
- Applications Platform scales, Belt scales, Silo hopper weighing

## INTERCHANGEABLE PRODUCTS

- ZEMIC H8C