

MS5 Sensor

S-Type Sensor



DESCRIPTION

Apply to crane scale, blending scale, packing scale, electromechanical scale, and special testing device.

OUTLINE DIMENSIONS in millimeters (mm)

200~1000kg

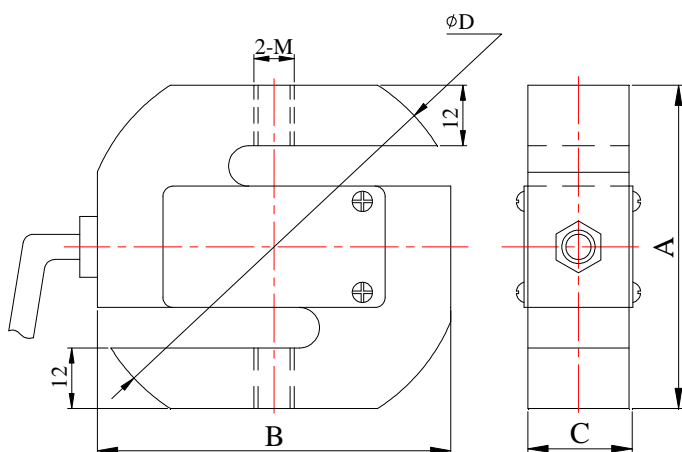

1.2~10t

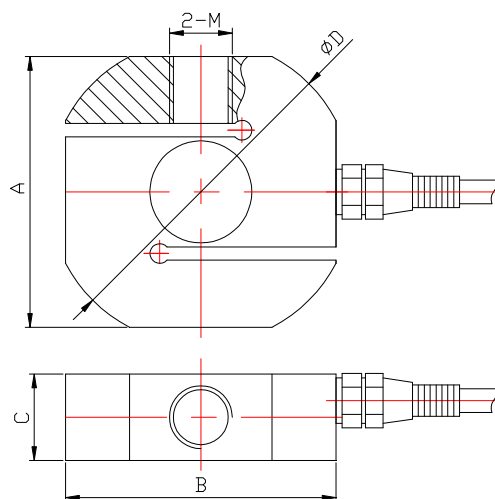

Capacity	Size mm				
kg	A	B	D	C	M
20,30,50, 75,100,150	64	70	76	12	M8
200,250, 300,500	64	70	76	20	M12
700,1000	64	70	76	25	M12

Capacity	Size mm				
kg	A	B	C	D	M
300-500	69	69	19	78	M12
1000	69	69	22	78	M16
1200-5000	90	90	32	95	M20
7500	90	90	40	95	M24
10000	110	110	50	120	M30X2

SPECIFICATIONS

Capacity	kg	20,30,50,75,100,150,200,250,300,500,700,1000
Rated output	mv/v	2.0±0.002(20~7500kg) 1.8±0.002(10t)
Non-linearity	%F.S	0.03
Hysteresis	%F.S	0.03
Creep in 30 minutes	%F.S	0.03
Zero balance	%F.S	±1
Input resistance	Ω	400±20
Output resistance	Ω	350±3
Insulation resistance	MΩ	≥5000
Excitation voltage	V	10V (maximum 15V) AC/DC
Environmental protection		IP67
Safe overload	%F.S	150
Ultimate overload	%F.S	300
Operating temperature range	℃	-10~+40
Material		Alloy steel & Stainless steel
Cable Length	m	3

Wiring Schematic Diagram

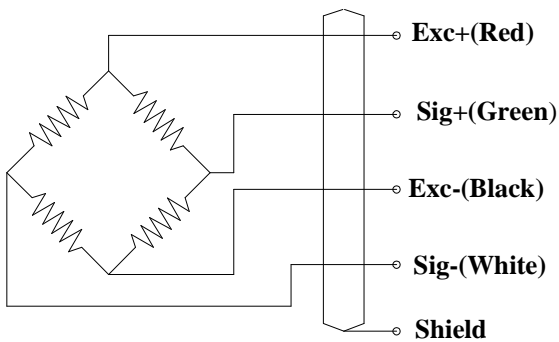

FEATURE

- Capacities 20~10000kg
- Alloy steel
- Hopper scales, crane scales