

# MZ3 Sensor

## High Capacity Compression Sensor



### DESCRIPTION

Column structure, anti-reversal design, good self-aligning ability, suitable for electronic platform scales, automobile testing facilities, hopper scales and other electronic weighing devices. Stainless steel construction, hermetically welded, oil-proof, waterproof and anti-corrosive gas and medium making it lightning protected in all kinds of environment.

### OUTLINE DIMENSIONS in millimeters (mm)

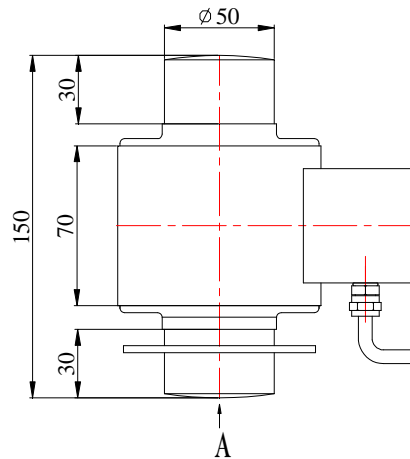
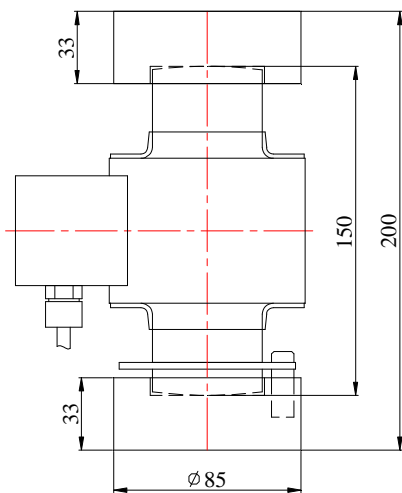

A Direction

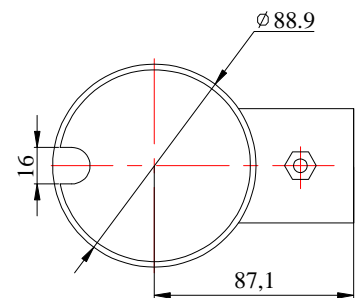

A Direction

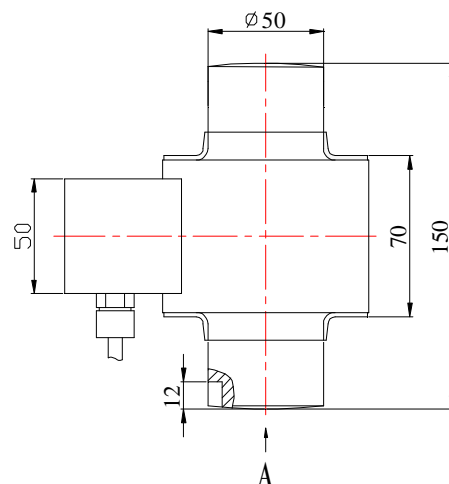
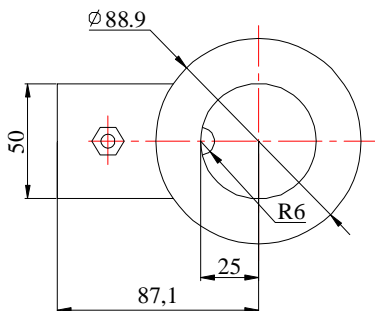

## SPECIFICATIONS

|                             |      |                               |
|-----------------------------|------|-------------------------------|
| Capacity                    | t    | 10,20,30,40,50                |
| Rated output                | mv/v | 2.0±0.1%                      |
| Non-linearity               | %F.S | 0.03                          |
| Hysteresis                  | %F.S | 0.03                          |
| Creep in 30 minutes         | %F.S | 0.03                          |
| Zero balance                | %F.S | ±1                            |
| Input resistance            | Ω    | 700±7                         |
| Output resistance           | Ω    | 703±3                         |
| Insulation resistance       | MΩ   | ≥5000                         |
| Excitation voltage          | V    | 10V (maximum 15V) AC/DC       |
| Environmental protection    |      | IP67                          |
| Safe overload               | %F.S | 1 50                          |
| Ultimate overload           | %F.S | 300                           |
| Operating temperature range | ℃    | -10~+40                       |
| Material                    |      | Alloy steel & Stainless steel |
| Cable Length                | m    | 15                            |

## Wiring Schematic Diagram

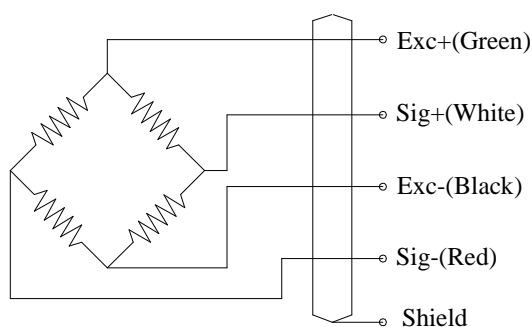

## FEATURE

- Capacities 10~50 ton
- Stainless steel housing
- Simple to install
- Self restoring rocking pi

## AVAILABLE

- 6-wire circuit
- Digital

## INTERCHANGEABLE PRODUCTS

- ZEMIC                                      BM14G
- VISHAY                                      Model ASC